

BRASS BALL VALVE

LEHRY MAKE Brass ball Valve Screwed End. Suitable for domestic water services, heating, air-conditioning plants and compressed air systems

- ❖ Female/female threads.
- ❖ Flat lever handle with decromet Plate for Anti Rust.
- ❖ Body in nickel-plated brass.
- ❖ Minimum and maximum working temperatures: -20°C, 120°C in absence of steam.
- ❖ Threads ISO228 (equivalent to DIN EN ISO 228 and BS EN ISO 228).

Specification :-

SL. No	Description	Material
1	Body	CW617N Brass in Nickel Plated
2	End Connection	CW617N Brass in Nickel Plated
3	Ball	58-2A Brass with Hard Chrome Plated
4	Stem	58-2A Brass
5	Handle	Steel Decromet Plated to prevent Corrosion
6	Ball Seat	PTFE
7	Sleeve	PVC
8	Stuffing	PTFE
9	Nut	Steel
10	Gland Nut	58-2A Brass

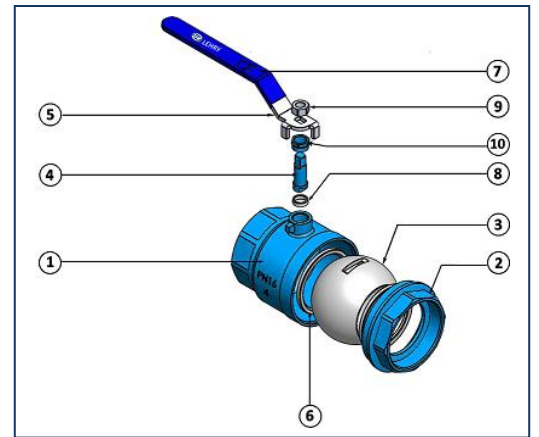

Typical Chemical Composition of Brass Valves								
Standard CW617N								
		Cu	Pb	Ni	Sn	Fe	Al	Zn
	Min. %	57.0	1.6	0.0	0.0	0.0	0.00	Balance
Max. %	59.0	2.5	0.3	0.3	0.3	0.05	Balance	

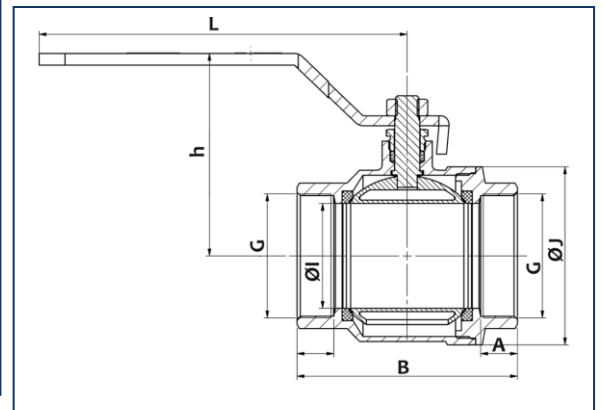
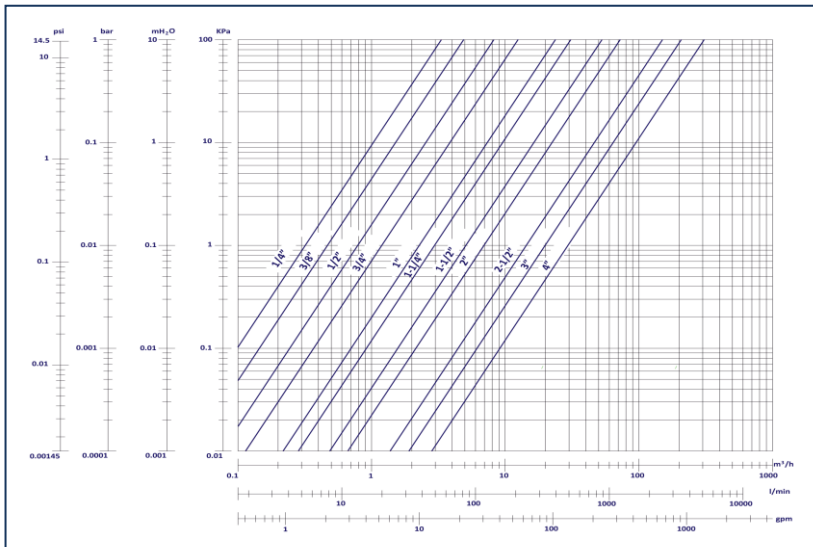

Dimensions :-

(All Dimension are in mm)

SIZE	DN	A	B	ØI	G	H	L	PN	ØJ
1/4"	8	10	42	10	¼	44.8	83.5	30	23
3/8"	10	10	42	10	3/8	44.8	83.5	30	23
1/2"	15	11.5	48	14	½	50	83.5	30	29
3/4"	20	12.5	55.5	19	¾	56.2	95.5	30	36.5
1"	25	14	65	24	1	61	108	30	44
1-¼"	32	16	79	31	1 ¼	72	131	25	55
1-½"	40	16	89	39	1 ½	91	145	25	67.5
2"	50	17	102.6	49	2	98	165	25	82.5
2-½"	65	22	132	63	2 ½	122	220	16	107
3"	80	23	148	73	3	138	275	16	121
4"	100	24.5	170	90	4	150	275	16	146.50

Lehry Instrumentation & Valves Pvt. Ltd.,

"Lehry Chambers" #78 (Old No: 51)Sembudoss Street,
 P.B No.1506, Parrys, Chennai - 600 001.
 Phone : 044 25226995/25225185/25226187/42163823/
 42625620/42625621. Fax : 044 25231715
 Email : info@lehry.com / Website : www.lehryvalves.com
 Branches : Chennai, Bangalore, Hyderabad, Mumbai, Noida, Pune