

INVESTMENT CASTING GLOBE VALVE

LEHRY MAKE Investment Casting Globe Valve

Technical Data: -

Manufacturing STD : Generally Conforming to BS 5352
 End Connection : Screwed Ends to BSP / BSPT / NPT (F)
 : Socket Weld Ends to ANSI B 16.11
 Inspection and Testing STD : BS 6755 (Part-I)

Specification: -

P.No	Nomenclature	Material
1	Body	ASTM A351 Gr. CF8 / CF8M
2	Bonnet	ASTM A351 Gr. CF8 / CF8M
3	Valve (Integral with Spindle)	ASTM A351 Gr. CF8 / CF8M
4	Spindle	AISI 304 / 316
5	Gland	AISI 304 / 316
6	Gland Nut	AISI 304 / 316
7	Stem Packing	PTFE / GRAFOIL
8	Hand Wheel	Cast Iron / Aluminium
9	Hand Wheel Nut & Washer	SS 304 / M.S. Plated

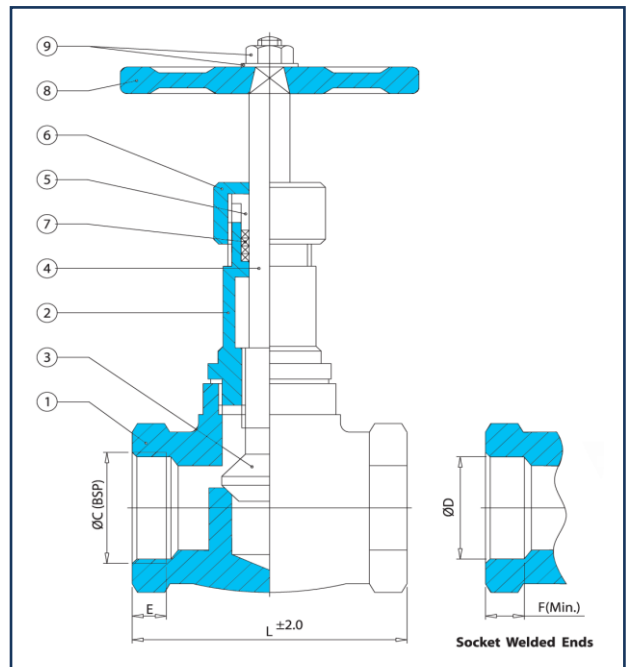
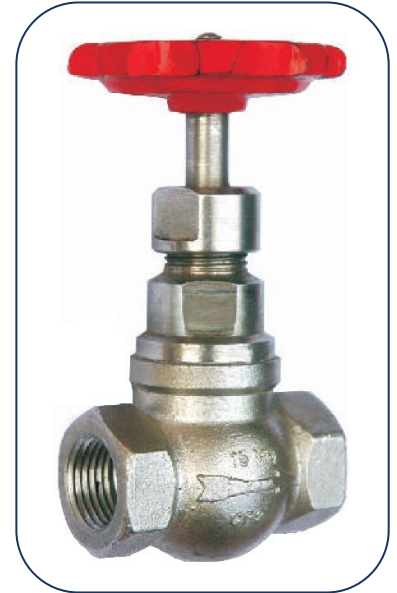

Test Pressure: -

Testing	Body	Seat
Hydraulic	425 Psig	300 Psig

Dimensions

(All Dimensions are in mm)

SIZE	L	SCREWED END		SOCKEWELD ENDS		
		ØC	E	ØD		F(Min.)
				Max.	Min.	
15	60	1/2"	13.56	22.22	21.72	9.65
20	70	3/4"	13.87	27.56	27.05	12.7
25	80	1"	17.35	34.29	33.78	12.7
40	100	1-1/2"	18.38	49.15	48.64	12.7
50	120	2"	19.23	61.62	61.11	15.75

Lehry Instrumentation & Valves Pvt. Ltd.,

"Lehry Chambers" #78 (Old No: 51) Sembudoss Street,
 P.B No.1506, Parrys, Chennai - 600 001.
 Phone : 044 25226995/25225185/25226187/42163823/
 42625620/42625621. Fax : 044 25231715
 Email : info@lehry.com / Website : www.lehryvalves.com
 Branches : Chennai, Bangalore, Hyderabad, Mumbai, Noida, Pune